

# ESQUEMA DE MONTAGEM - CÔMODA SARAH

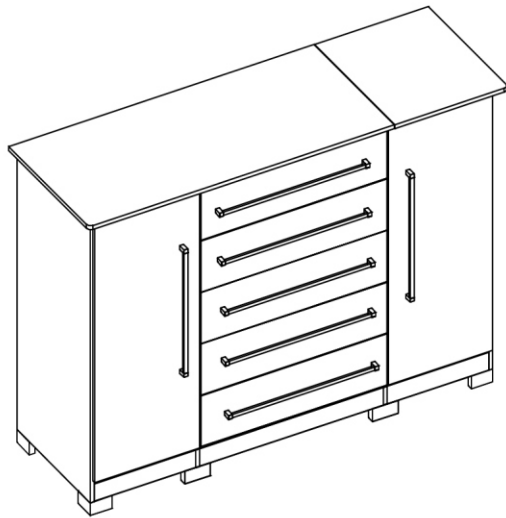

FUNDOS

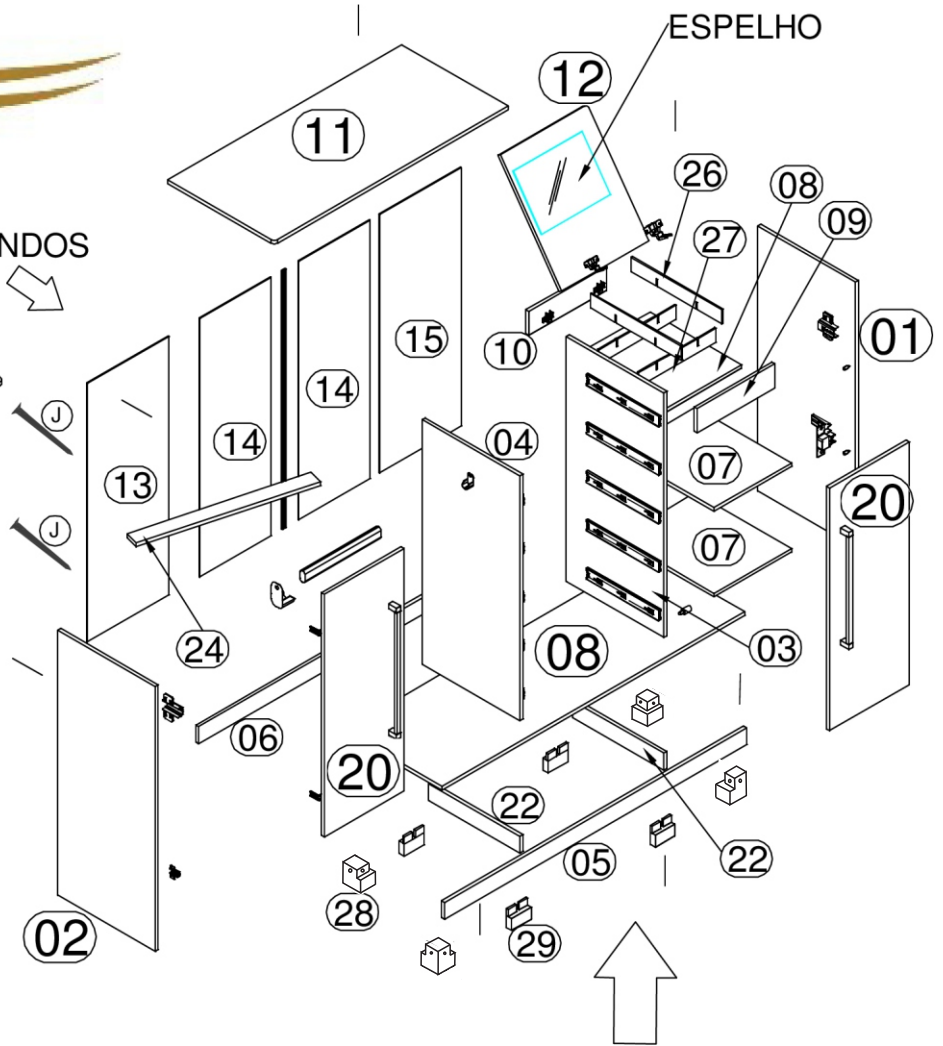

## DIMENSÕES - CÔMODA SARAH

LARGURA: 1445 mm  
 PROFUND.: 515 mm  
 ALTURA: 1220 mm

## **ATENÇÃO:**

**A FIXAÇÃO DOS PUXADORES DEVE SER FEITA APÓS O TERMINO DA MONTAGEM DA CÔMODA POSICIONANDO OS PUXADORES NA FURAÇÃO DESEJADA PARA POSTERIORMENTE PERFURAR.**

## **IMPORTANTE:**













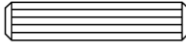
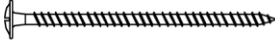

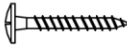

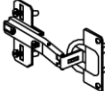
Utilize as ferramentas corretamente, evitando o uso de materiais que possam causar danos ao produto.



COMODA SARAH	No.	MATERIAL	QTD	COMPR	LARG	ESPE.
LATERAL EXTERNA DIREITA	1	MDF	1	1149	470	15
LATERAL EXTERNA ESQUERDA	2	MDF	1	1149	470	15
LATERAL INTERNA DIREITA	3	MDF	1	1062	470	15
LATERAL INTERNA ESQUERDA	4	MDF	1	1062	470	15
RODAPÉ FRONTAL	5	MDF	1	1459	70	15
RODAPÉ TRAZEIRO	6	MDF	1	1459	70	15
PRATELEIRA MOVÉL	7	MDF	2	465	375	15
FUNDO DA COLMÉIA	8	MDF	1	455	375	15
TRAV.FRONTAL COLMÉIA	9	MDF	1	375	100	15
TRAV.TRAZEIRA COLMÉIA	10	MDF	1	375	85	15
TAMPO MAIOR	11	MDF	1	1130	515	20
TAMPO DA COLMÉIA	12	MDF	1	420	515	20
FUNDO TRASEIRO CABIDEIRO	13	MDF	1	1080	393	3
FUNDO TRASEIRO CENTRAL	14	MDF	2	1080	345	3
FUNDO TRASEIRO COLMÉIA	15	MDF	1	990	393	3
FRENTE GAVETA	16	MDF	5	690	201	15
LATERAL GAVETA	17	MDF	10	435	150	15
CONTRA FUNDO	18	MDF	5	650	180	15
FUNDO GAVETA	19	MDF	5	641	450	3
PORTA DIREITA	20	MDF	1	1070	386	15
PORTA ESQUERDA	21	MDF	1	1070	386	15
TRAVA DO RODAPÉ	22	MDF	2	440	70	15
BASE DA COMODA	23	MDF	1	1459	470	15
TRAVA DA COMODA	24	MDF	1	681	60	15
APOIO DAS GAVETAS	25	MDF	5	435	60	15
DIVISÓRIA COLMÉIA MAIOR	26	MDF	2	438	60	6
DIVISÓRIA COLMÉIA MENOR	27	MDF	2	374	60	6
PEZINHO CANTONEIRA	28	MADEIRA	4			
PEZINHO RETO	29	MADEIRA	4			

NOTA: "GARANTIA PARA DEFEITO DE FÁBRICA. CONFORME LEI Nº 8.078, ARTIGO 26 DO CÓDIGO DO CONSUMIDOR."

# CÔMODA SARAH

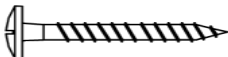
CÓD.	QTDDE	DESCRIÇÃO	ILUSTRAÇÃO
A	44	PINO MINIFIX TWISTER 35 x 8MM	
B	44	TAMBOR MINIFIX 15 X 12MM	
C	44	TAMPA DO MINIFIX 17 X 17MM	
D	62	CAVILHAS 8 X 30MM	
E	08	PARAFUSO 4,5X45 FLANG. P. PLÁST.	
F	04	CANTONEIRA METÁLICA	
G	28	PARAFUSO 3,5 X 25 FLANGEADO	
H	92	PARAFUSO 3,5 X 14 CHATA	
I	45	PREGO 10X10C/C	
J	02	DOBRADIÇA 35mm	
K	02	CALÇO DOBRADIÇA 35mm	
L	04	DOBRADIÇA 26mm	
M	04	CALÇO DOBRADIÇA 26mm	
N	10	DISPOSITIVO TRAPÉZIO	
O	05	CORREDIÇA TELESCÓPICA 450mm	
P	07	PUXADOR ALUMÍNIO 510mm	
Q	01	PERFIL "H" 1060mm	
R	02	SUPORTE CABIDEIRO	
S	01	CABIDEIRO 366mm	
T	01	ESPELHO 350X300X3mm	
U	12	PARAFUSO 3,5 X 30 FLANGEADO	

# 1 PASSO PASO STEP

INICIE MONTANDO A LATERAL ESQUERDA, DIREITA E PARAFUSE ÀS CORREDIÇAS

APLIQUE CORREDIÇAS SOBRE AS DIVISÓRIAS INDICADAS.

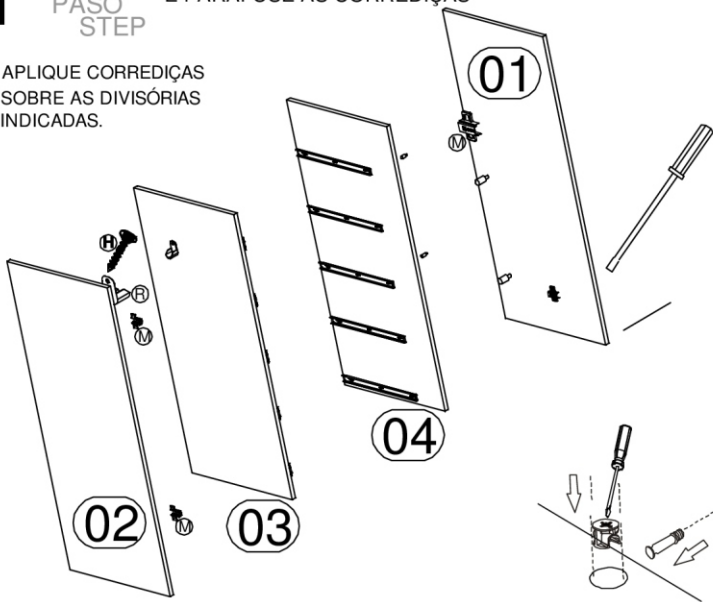

# 2 PASSO PASO STEP

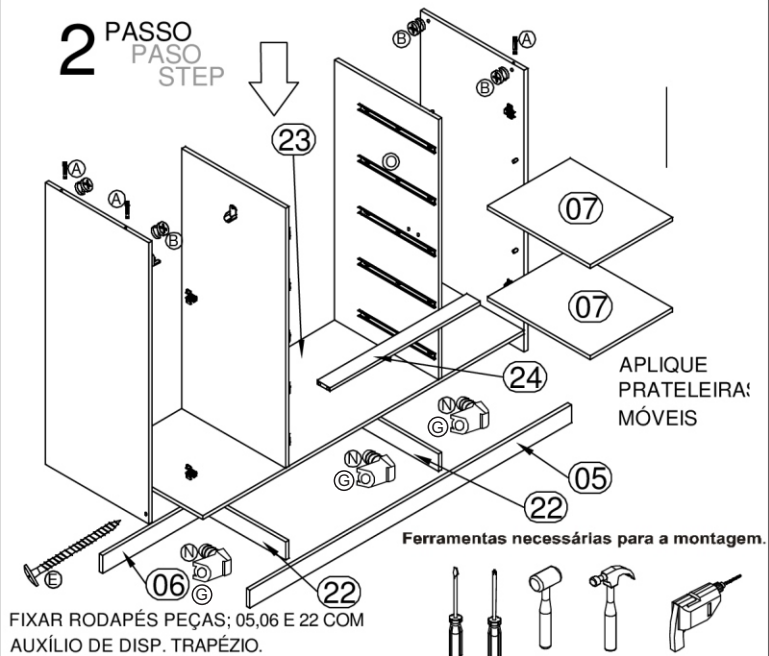

# 3 PASSO PASO STEP

APLIQUE O TAMPO SOBRE A ESTRUTURA DO MÓVEL

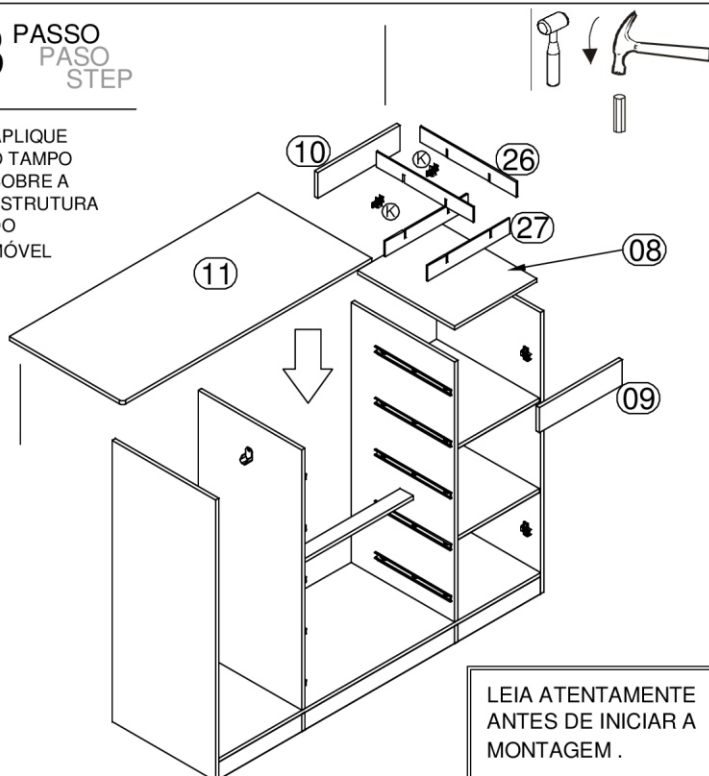

# 4 PASSO PASO STEP

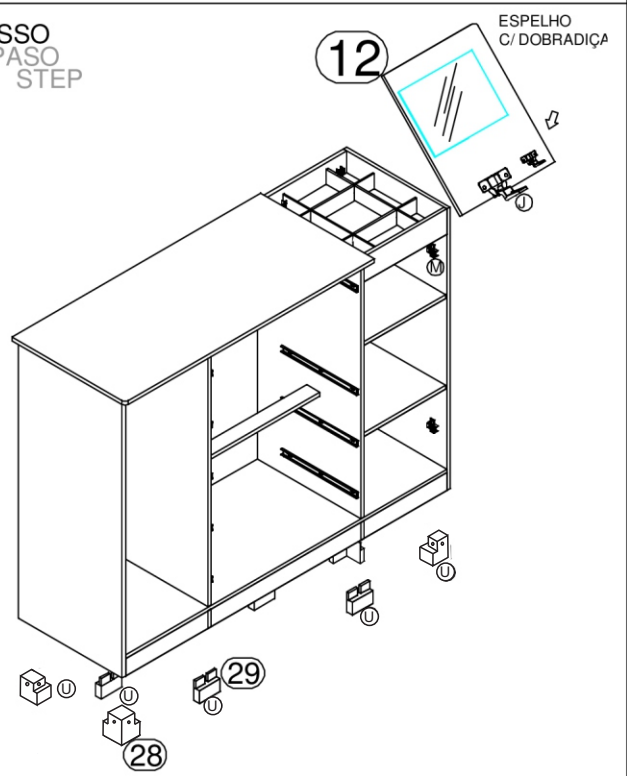

# 5 PASSO PASO STEP

CAMPO PARA MONTAGEM DE GAVETAS E SUAS RESPECTIVAS PEÇAS.

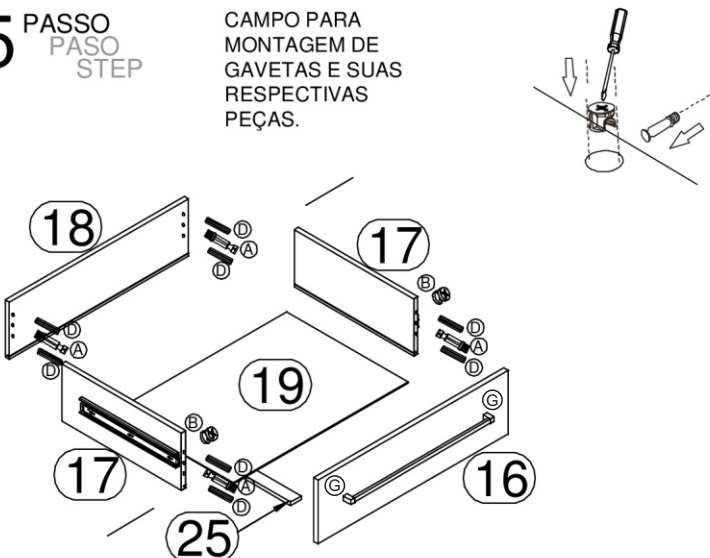

# 6 PASSO PASO STEP

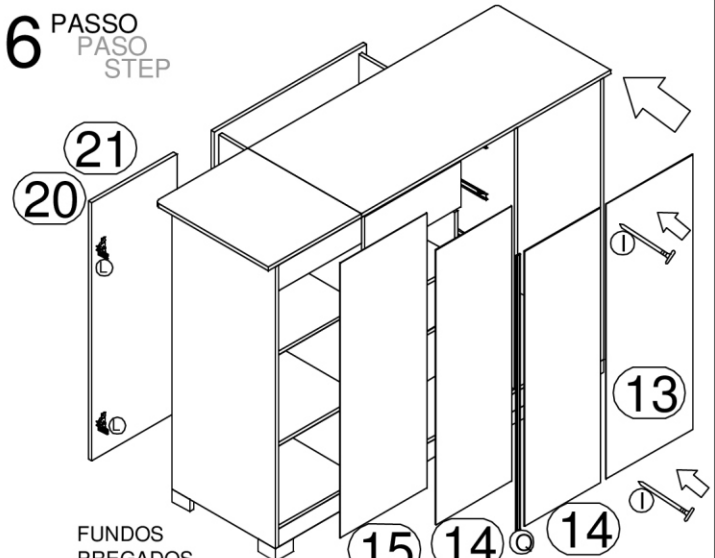

FÊNIX INDÚSTRIA DE MÓVEIS  
R: FRUTUOSO H. DE MEDEIROS, 2-68 - DISTR. INDUSTRIAL III  
PABX (17) 3485-1253 - CEP 15520-000 - VALENTIM GENTIL/SP.  
E-MAIL: [fenix@camasfenix.com.br](mailto:fenix@camasfenix.com.br) / [www.camasfenix.com.br](http://www.camasfenix.com.br)

FUNDOS PREGADOS PARA FIRMEZA E ESTABILIDADE DO MÓVEL.

