

ROUPEIRO MUSTANG 2 PORTAS

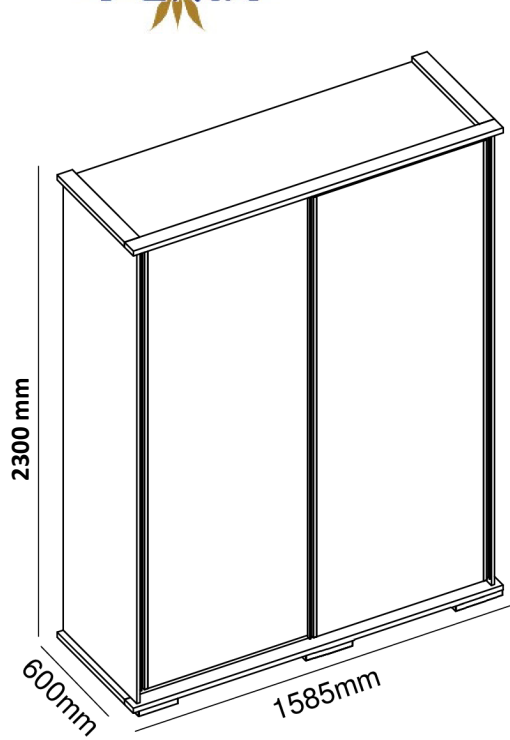

FUNDOS

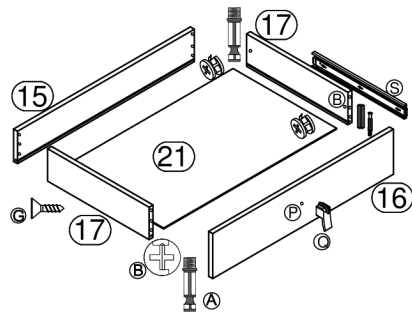

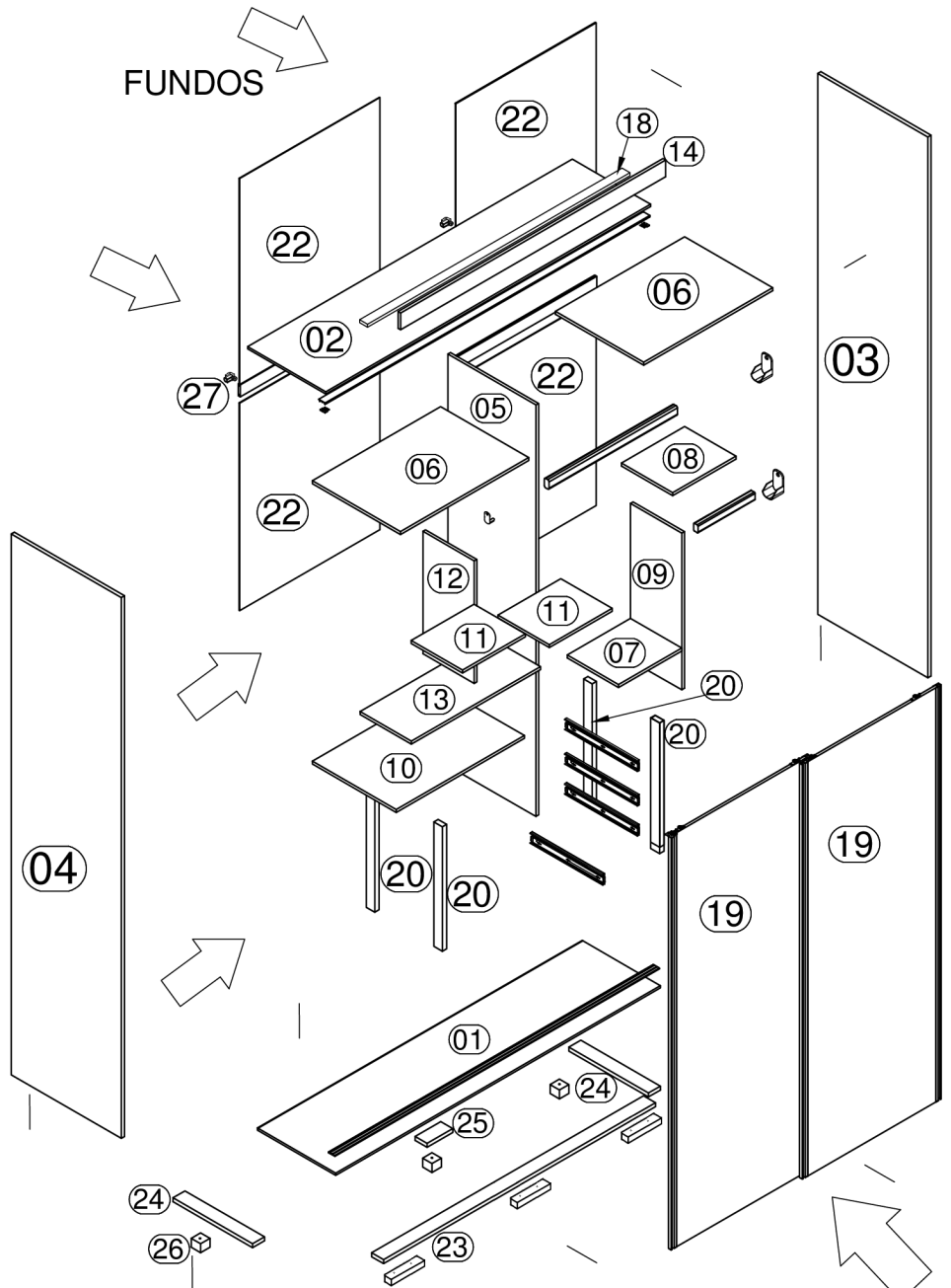



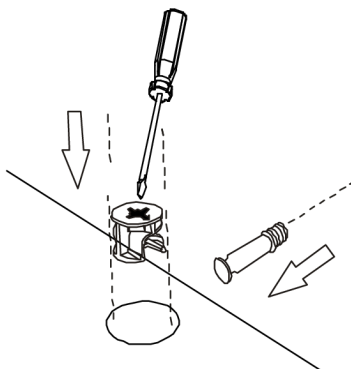







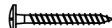

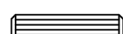

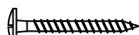



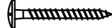

DETALHE DE GAVETAS

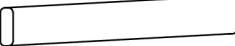
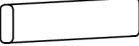
FIXAÇÃO DO MINIFIX



| ROUP. MUSTANG 02 PORTAS | Nº | MATERIAL | QTD | COMPR | LARG | ESPEŠ. |
|--------------------------|----|----------|-----|-------|------|--------|
| BASE | 1 | MDF | 1 | 1525 | 580 | 15 |
| CHAPÉU | 2 | MDF | 1 | 1525 | 560 | 15 |
| LATERAL EXTERNA DIREITA | 3 | MDF | 1 | 2200 | 580 | 15 |
| LATERAL EXTERNA ESQUERDA | 4 | MDF | 1 | 2200 | 580 | 15 |
| DIVISÓRIA CENTRAL | 5 | MDF | 1 | 2090 | 515 | 15 |
| PRATELEIRAS SUPERIOR | 6 | MDF | 2 | 755 | 493 | 15 |
| PRATELEIRA CALCEIRO | 7 | MDF | 1 | 370 | 300 | 15 |
| TAMPO DO CALCEIRO | 8 | MDF | 1 | 390 | 300 | 15 |
| LATERAL DO CALCEIRO | 9 | MDF | 1 | 755 | 300 | 15 |
| PRATELEIRA DO GAVETEIRO | 10 | MDF | 1 | 755 | 470 | 15 |
| PRATELEIRA MENOR COLMÉIA | 11 | MDF | 2 | 370 | 300 | 15 |
| DIVISÓRIA DA COLMÉIA | 12 | MDF | 1 | 620 | 300 | 15 |
| PRATELEIRA MAIOR COLMÉIA | 13 | MDF | 1 | 755 | 300 | 15 |
| VISTA FRONTAL | 14 | MDF | 1 | 1555 | 125 | 15 |
| CONTRA FUNDO | 15 | MDF | 4 | 680 | 110 | 15 |
| FRENTE DE GAVETA | 16 | MDF | 4 | 695 | 150 | 15 |
| LATERAL DE GAVETAS | 17 | MDF | 8 | 385 | 110 | 15 |
| TALA FIXAÇÃO DA VISTA | 18 | MDF | 1 | 152 | 40 | 15 |
| PORTAS | 19 | MDF | 2 | 2060 | 745 | 15 |
| DISTANCIADOR GAVETAS | 20 | MDF | 4 | 625 | 47 | 25 |
| FUNDO DE GAVETAS | 21 | MDF | 4 | 665 | 400 | 15 |
| FUNDO TRAZEIRO | 22 | MDF | 4 | 1027 | 765 | 15 |
| MOLDURA FRONTAL | 23 | MDF | 1 | 1585 | 70 | 20 |
| MOLDURA LATERAL | 24 | MDF | 2 | 530 | 70 | 20 |
| APOIO DO PÉ | 25 | MDF | 1 | 200 | 70 | 20 |
| PÉZINHOS | 26 | MADEIRA | 3 | 65 | 55 | 55 |
| PINAZO | 27 | MDF | 2 | 755 | 60 | 15 |
| PÉZINHOS | 28 | MADEIRA | 3 | 200 | 65 | 65 |

| KIT ROUPEIRO MUSTANG 2 PORTAS | | | |
|-------------------------------|--------|-----------------------------|---|
| CÓD. | QTDADE | DESCRIÇÃO | ILUSTRAÇÃO |
| A | 50 | PINO MINIFIX 32mm |  |
| B | 54 | TAMBOR MINIFIX 12x15mm |  |
| C | 54 | TAMPA MINIFIX 15mm |  |
| D | 02 | PINO HASTE DUPLA 63mm |  |
| E | 18 | PARAFUSO 7 X 40 ESCAREADO |  |
| F | 08 | PARAFUSO 3,5 X 25 FLANG. |  |
| G | 60 | PARAFUSO 3,5 X 12 CHATA |  |
| H | 38 | CAVILHA 8 X 30 |  |
| I | 10 | PREGOS 10 X 10 C/C |  |
| J | 12 | PARAFUSO 4,5 X 35 FLANGEADO |  |
| K | 04 | SUORTE CABIDEIRO OBLONGO |  |
| L | 08 | SUORTE PRATELEIRA 6X8 |  |
| M | 01 | TRILHO SUP. 1523mm |  |
| N | 01 | TRILHO INFERIOR 1523mm |  |
| O | 04 | PARAFUSO 3,5 X 30 CH. |  |
| P | 42 | PARAFUSO 3,5 X 16 CHATA |  |
| Q | 04 | PUXADOR SIMPLES 1 FURO |  |
| R | 02 | PUXADOR ANODIZADO 2058mm |  |
| S | 04 | CORREDIÇA TELESCÓPICA 400mm |  |
| T | 02 | CABIDEIRO OBLONGO 745mm |  |
| U | 01 | CABIDEIRO OBLONGO 360mm |  |
| V | 02 | PERFIL ESTRUTURAL 2058mm |  |
| W | 04 | RODÍZIO REGULÁVEL C/ MOLA |  |
| X | 04 | GUIA SUPERIOR 26mm |  |
| Y | 02 | FREIO TRAVA |  |
| Z | 02 | PARAFUSO 3,5 X 20 CHATA |  |
| AA | 04 | DISPOSITIVO TRAPÉZIO |  |

1 PASSO
PASO
STEP

UTILIZE FERRAMENTA
CORRESPONDENTE (FENDA OU
PHILIPS)

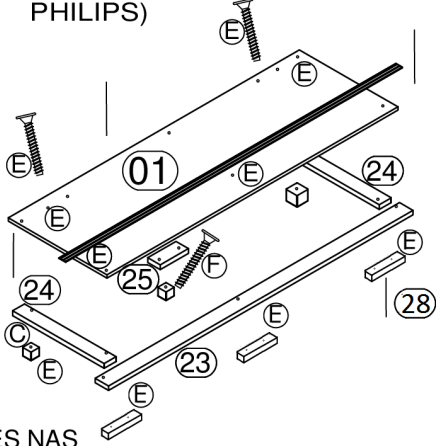

FIXE OS PÉS NAS
MOLDURAS E EM
SEGUIDA A MOLDURA
SOB À BASE

**LEIA ATENTAMENTE
ANTES DE INICIAR A
MONTAGEM.**

2 PASSO
PASO
STEP

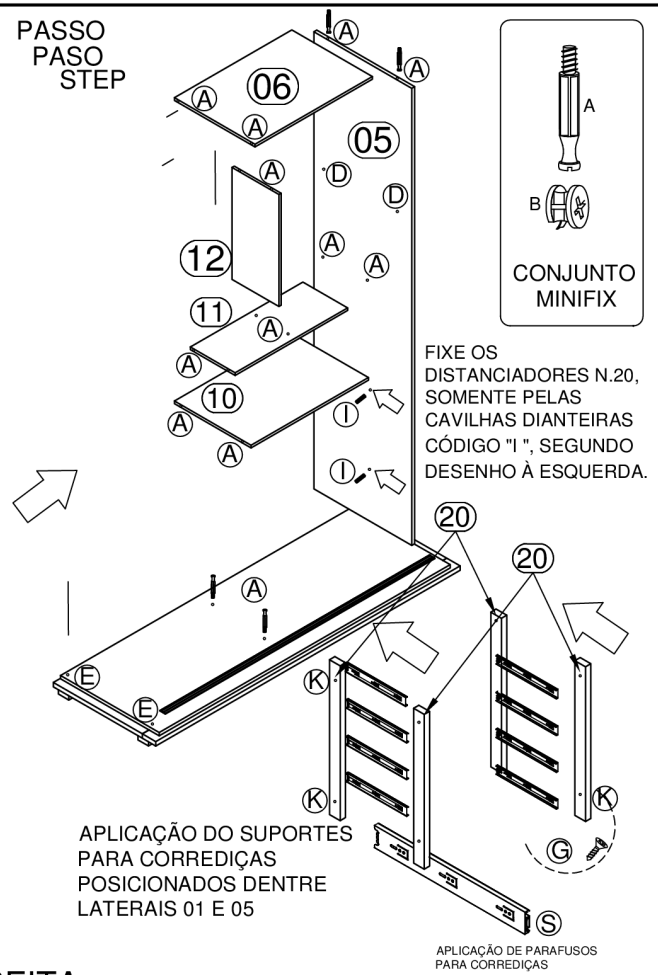

FIXE OS
DISTANCIADORES N.20,
SOMENTE PELAS
CAVILHAS DIAANTEIRAS
CÓDIGO "I", SEGUNDO
DESENHO À ESQUERDA.

APLICAÇÃO DO SUPORTES
PARA CORRIDIÇAS
POSICIONADOS DENTRE
LATERAIS 01 E 05

APLICAÇÃO DE PARAFUSOS
PARA CORRIDIÇAS

3 PASSO
PASO
STEP

DUAS OPÇÕES DE MONTAGEM NA DIREITA
DO MÓVEL.

FIXAR LATERAIS EXTERNA NA
BASE,
E PRATELEIRAS
NA SEQUÊNCIA.

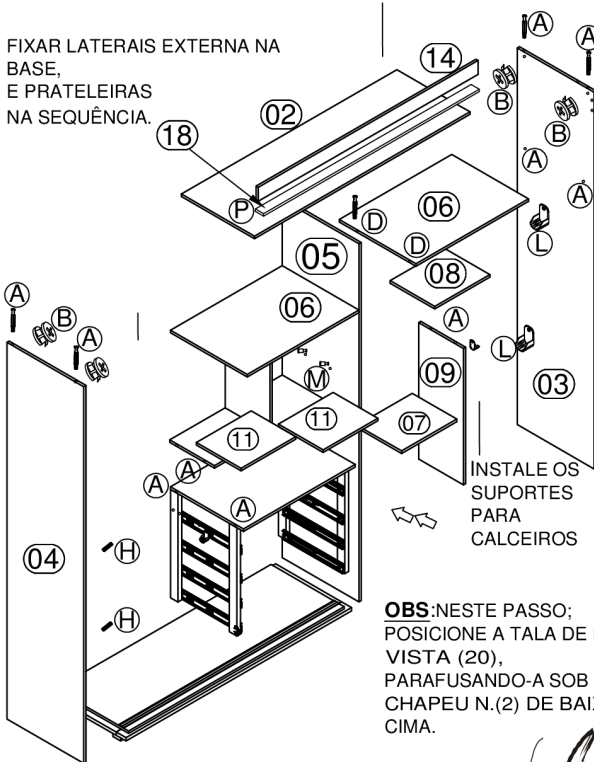

OPCIONALMENTE

MONTE A PÇ N.
09 NA
HORIZONTAL
ENTRE A LAT. N.
03 E DIV. N. 05,
DISPENSANDO
ÀS
PEÇAS N. 07/ 08
DA MONTAGEM
CO-
MO NO
EXEMPLO
ABAIXO.

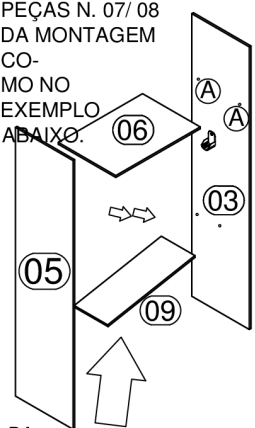

INSTALE OS
SUPORTES
PARA
CALCEIROS

OBS: NESTE PASSO;
POSICIONE A TALA DE FIX. DA
VISTA (20),
PARAFUSANDO-A SOB O
CHAPEU N.(2) DE BAIXO P/
CIMA.

OPÇÃO 2 PARA
MONTAGEM

4 PASSO
PASO
STEP

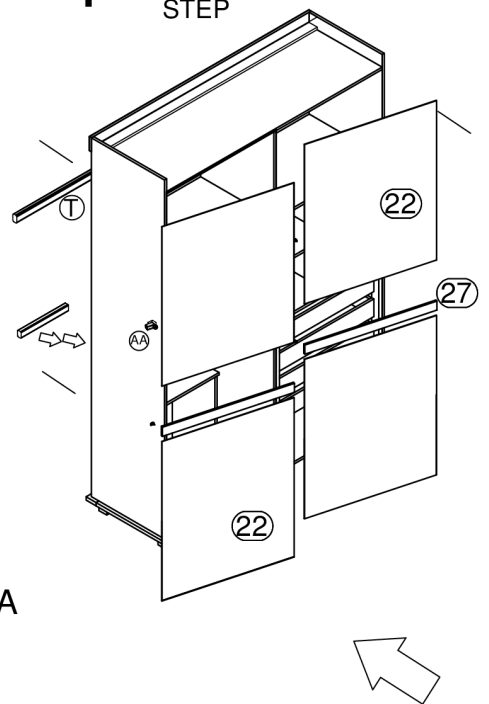

FUNDOS

Ferramentas necessárias para a montagem.

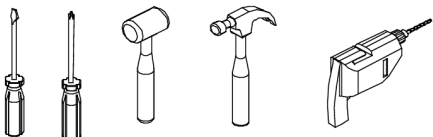

5 PASSO
PASO
STEP

PREPARE ÀS PORTAS
CONFORME DESENHO.

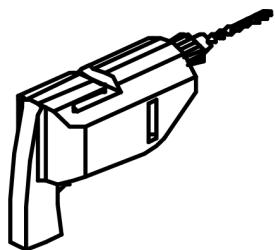
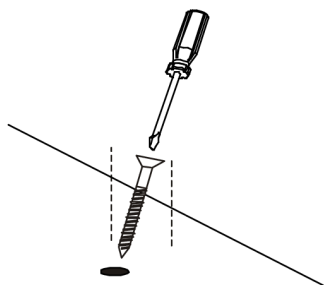

RODÍZIO INFERIOR DE
PORTAS

PREPARE
ÀS
PORTAS
CONFORME
DESENHO.

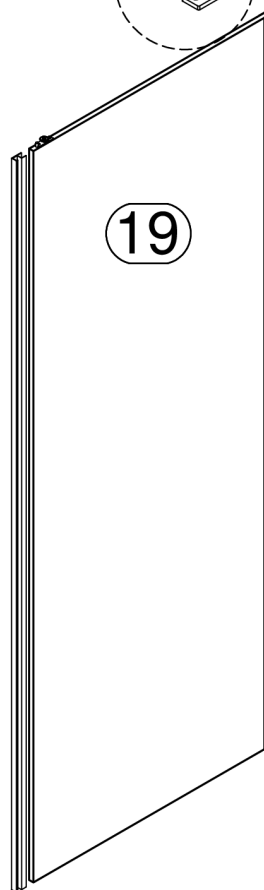
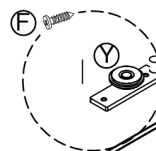
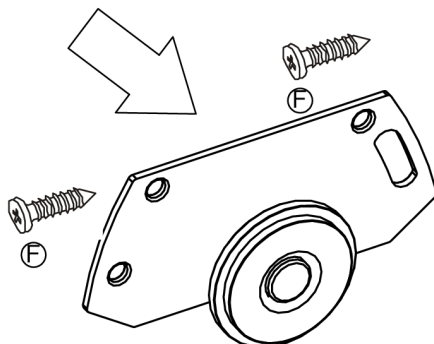

6 PASSO
PASO
STEP

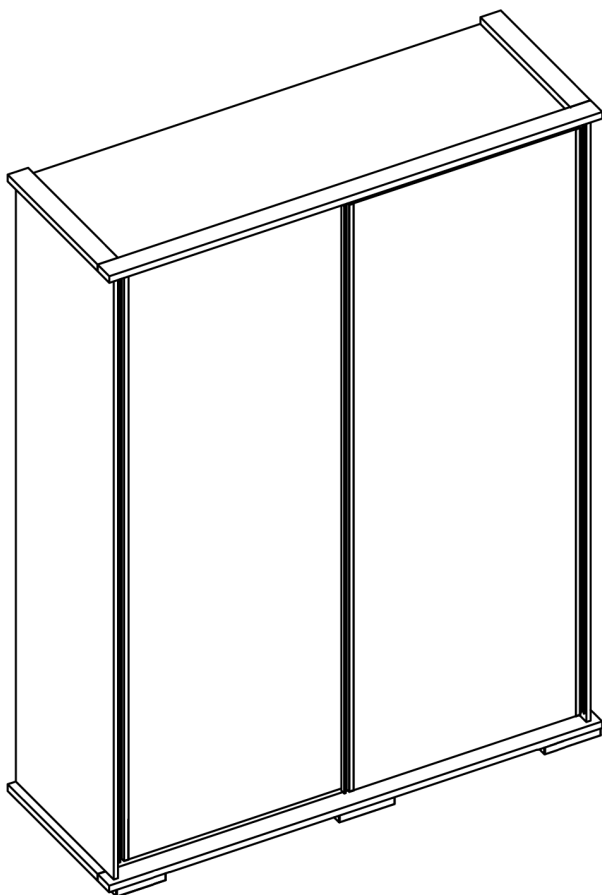

IMPORTANTE:

Utilize as ferramentas corretamente, evitando o uso de materiais que possam causar danos ao produto.



chave
de fenda



chave
philips

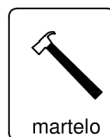

martelo

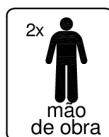

2x
mão
de obra

NOTA: "reservamos o direito de fazer modificações de ordem técnica neste produto, sem prévia notificação."

FÊNIX INDÚSTRIA DE MÓVEIS
R: FRUTUOSO H. DE MEDEIROS, 2-68 - DISTR. INDUSTRIAL III
TEL.: (17) 3485-1253
VALENTIM GENTIL - SP/ CEP 15520-000
E-MAIL: fenix@camasfenix.com.br/www.camasfenix.com.br

