

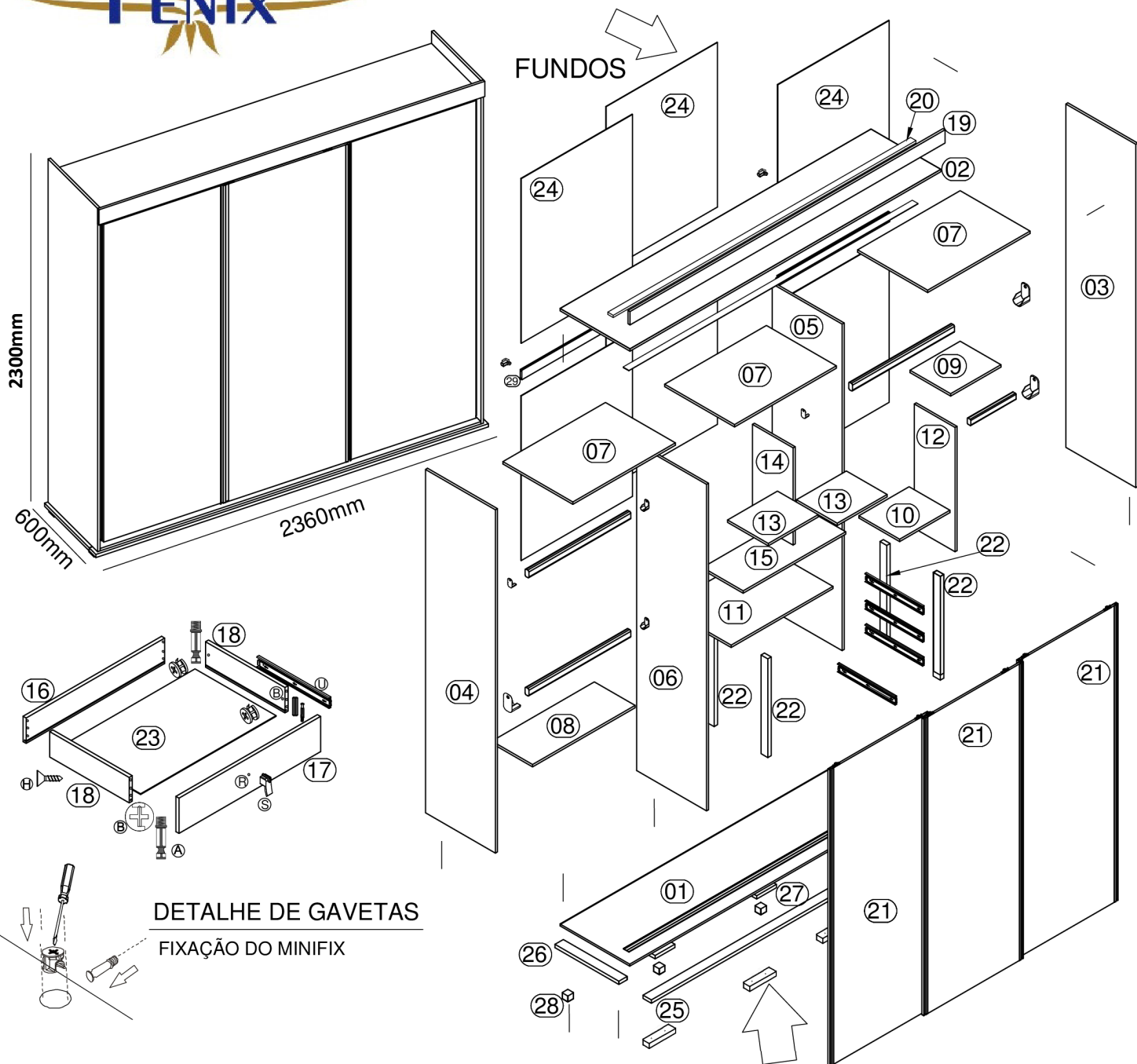















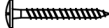
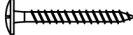

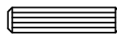



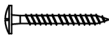

# ROUPEIRO MUSTANG 3 PORTAS

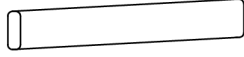
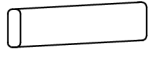

### DETALHE DE GAVETAS

FIXAÇÃO DO MINIFIX

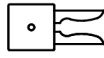
ROUP. MUSTANG 03 PORTAS	Nº	MATERIAL	QTD	COMPR	LARG	ESPES.
BASE	1	MDF	1	2295	580	15
CHAPÉU	2	MDF	1	2295	560	15
LATERAL EXTERNA DIREITA	3	MDF	1	2200	580	15
LATERAL EXTERNA ESQUERDA	4	MDF	1	2200	580	15
DIVISÓRIA INTERNA DIREITA	5	MDF	1	2090	515	15
DIVISÓRIA INTERNA ESQUERDA	6	MDF	1	2090	515	15
PRATELEIRAS SUPERIOR	7	MDF	3	755	493	15
PRATELEIRA CALÇEIRO MAIOR	8	MDF	1	755	300	15
TAMPO CALÇEIRO MENOR	9	MDF	1	390	300	15
PRATELEIRA MENOR	10	MDF	1	370	300	15
PRATELEIRA DO GAVETEIRO	11	MDF	1	755	470	15
LATERAL DO CALÇEIRO	12	MDF	1	755	300	15
PRATELEIRA MENOR COLMÉIA	13	MDF	2	370	300	15
DIVISÓRIA DA COLMÉIA	14	MDF	1	620	300	15
PRATELEIRA MAIOR COLMÉIA	15	MDF	1	755	300	15
CONTRA FUNDO	16	MDF	4	680	110	15
FRENTE DE GAVETA	17	MDF	4	695	150	15
LATERAL DE GAVETAS	18	MDF	8	385	110	15
VISTA FRONTAL	19	MDF	1	2325	125	15
TALA FIXAÇÃO DA VISTA	20	MDF	1	2320	40	15
PORTAS	21	MDF	3	2060	745	15
DISTANCIADOR GAVETAS	22	MDF	4	625	47	25
FUNDO DE GAVETAS	23	MDF	4	665	400	3
FUNDO TRAZEIRO	24	MDF	6	1027	765	3
MOLDURA FRONTAL	25	MDF	1	2360	70	20
MOLDURA LATERAL	26	MDF	2	530	70	20
APOIO DO PÉ	27	MDF	2	200	70	20
PÉZINHOS	28	MADEIRA	4	65	55	55
PINAZO	29	MDF	3	755	60	15
PÉZINHOS	29	MADEIRA	4	200	65	65

KIT ROUPEIRO MUSTANG 3 PORTAS			
CÓD.	QDTADE	DESCRIÇÃO	ILUSTRAÇÃO
A	55	PINO MINIFIX 32mm	
B	63	TAMBOR MINIFIX 12x15mm	
C	63	TAMPA MINIFIX 15mm	
D	04	PINO HASTE DUPLA 63mm	
E	24	PARAFUSO 7 X 40 ESCAREADO	
F	10	PARAFUSO 3,5 X 25 FLANG.	
G	12	PARAFUSO 4,5 X 35 FLANGEADO	
H	30	PARAFUSO 3,5 X 12 CHATA	
I	50	CAVILHA 8 X 30	
J	20	PREGOS 10 X 10 C/C	
K	08	SUPORTE CABIDEIRO OBLONGO	
L	08	SUPORTE PRATELEIRA 6X8	
M	01	TRILHO SUP. 2293mm	
N	01	TRILHO INFERIOR 2293mm	
O	06	PARAFUSO 3,5 X 30 CH.	
P	42	PARAFUSO 3,5 X 16 CHATA	
Q	04	PUXADOR SIMPLES 1 FURO	
R	04	PUXADOR ANODIZADO 2058mm	
S	04	CORREDIÇA TELESCÓPICA 400mm	
T	04	CABIDEIRO OBLONGO 745mm	
U	01	CABIDEIRO OBLONGO 360mm	
V	02	PERFIL ESTRUTURAL 2058mml	
W	06	RODÍZIO REGULÁVEL C/ MOLA	
X	06	GUIA SUPERIOR 26mm	
Y	04	FREIO TRAVA	
Z	04	PARAFUSO 3,5 X 20 CHATA	
AA	06	DISPOSITIVO TRAPÉZIO	

**1** PASSO  
PASO  
STEP

UTILIZE FERRAMENTA  
CORRESPONDENTE (FENDA OU  
PHILIPS)

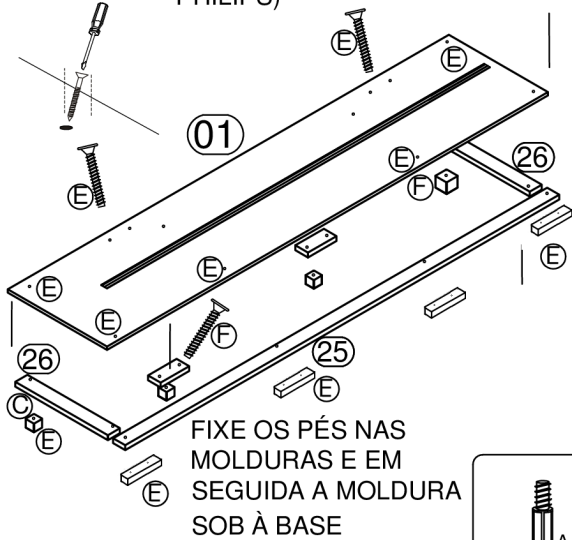

FIXE OS PÉS NAS  
MOLDURAS E EM  
SEGUIDA A MOLDURA  
SOB À BASE

**LEIA ATENTAMENTE  
ANTES DE INICIAR A  
MONTAGEM .**

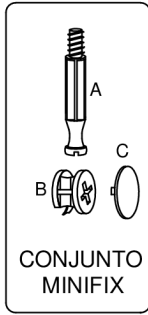

CONJUNTO  
MINIFIX

**2** PASSO  
PASO  
STEP

UTILIZE  
MARTELO DE  
BORRACHA  
PARA  
COLOCAÇÃO  
DE CAVILHAS E  
SUPORTES DE  
PRATELEIRAS

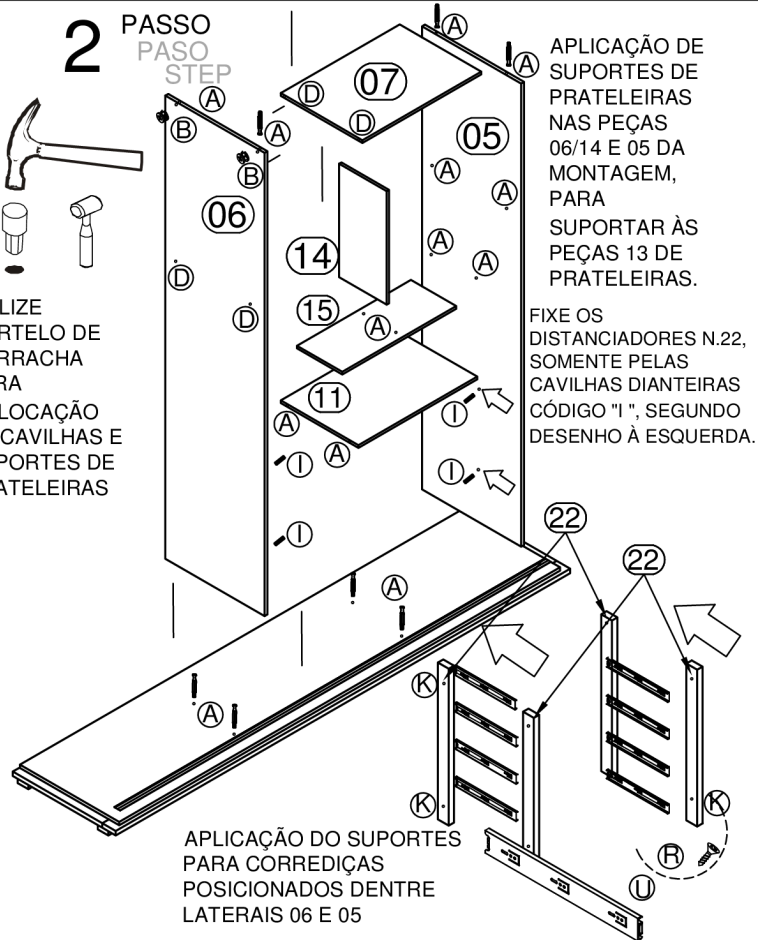
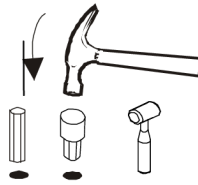

APLICAÇÃO DE  
SUPORTES DE  
PRATELEIRAS  
NAS PEÇAS  
06/14 E 05 DA  
MONTAGEM,  
PARA  
SUPPORTAR ÀS  
PEÇAS 13 DE  
PRATELEIRAS.

FIXE OS  
DISTANCIADORES N.22,  
SOMENTE PELAS  
CAVILHAS DIANTEIRAS  
CÓDIGO "I", SEGUNDO  
DESENHO À ESQUERDA.

APLICAÇÃO DO SUPORTES  
PARA CORREDIÇAS  
POSICIONADOS DENTRE  
LATERAIS 06 E 05

APLICAÇÃO DE PARAFUSOS  
PARA CORREDIÇAS

**3** PASSO  
PASO  
STEP

DUAS OPÇÕES DE MONTAGEM NA DIREITA  
DO MÓVEL.

FIXAR LATERAIS EXTERNA NA  
BASE,  
E PRATELEIRAS  
NA SEQUÊNCIA.

INSTALE  
OS  
SUPORTES  
PARA  
CALÇEIROS

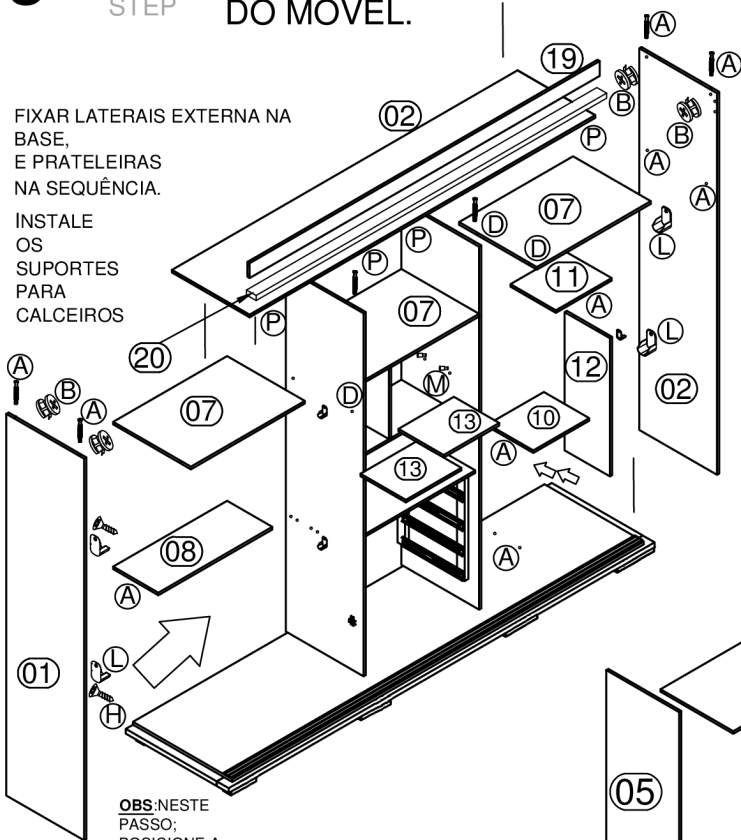

**OBS:**NESTE  
PASSO:  
POSICIONE A  
TALA DE FIX.  
DA VISTA (20),  
PARAFUSANDO-A  
SOB O  
CHAPEU N.(2)  
DE BAIXO P/  
CIMA.

**OPCIONALMENTE**

MONTE A PÇ N.  
12 NA  
HORIZONTAL  
ENTRE A LAT.  
N. 02 E DIV. N.  
05,  
DISPENSANDO  
ÀS  
PEÇAS N. 10/ 11  
DA MONTAGEM  
COMO NO  
EXEMPLO  
SUPERIOR.

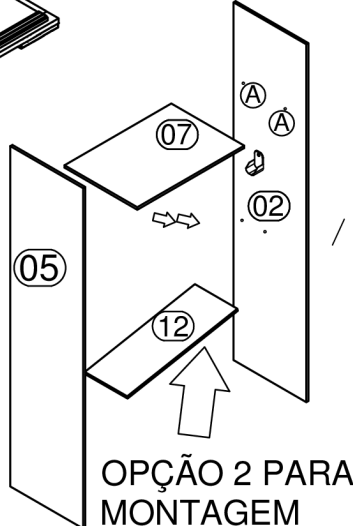

OPÇÃO 2 PARA  
MONTAGEM

**4** PASSO  
PASO  
STEP

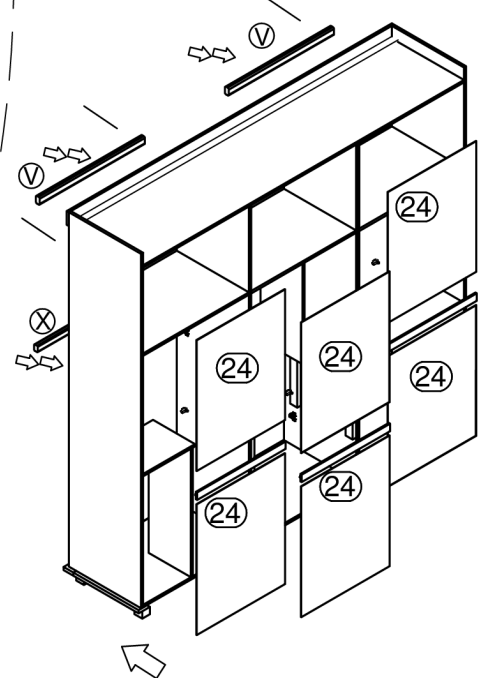

Ferramentas necessárias para a montagem.

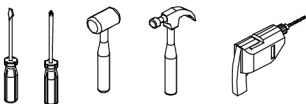

**5** PASSO  
PASO  
STEP

PREPARE ÀS PORTAS  
CONFORME DESENHO.

PREPARE  
ÀS  
PORTAS  
CONFORME  
DESENHO.

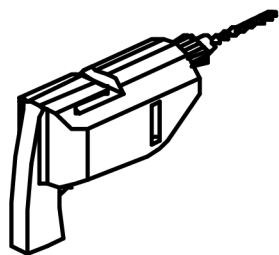
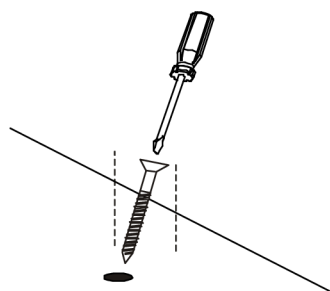

RODÍZIO INFERIOR DE  
PORTAS

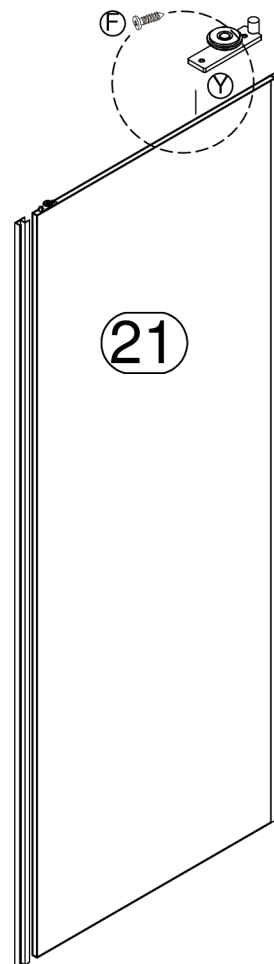
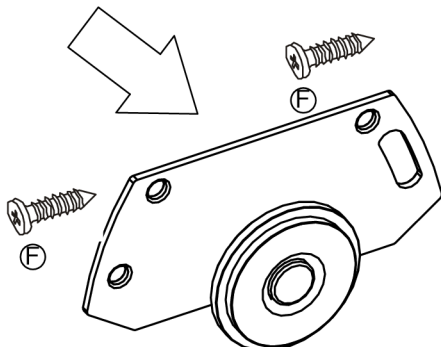

**6** PASSO  
PASO  
STEP

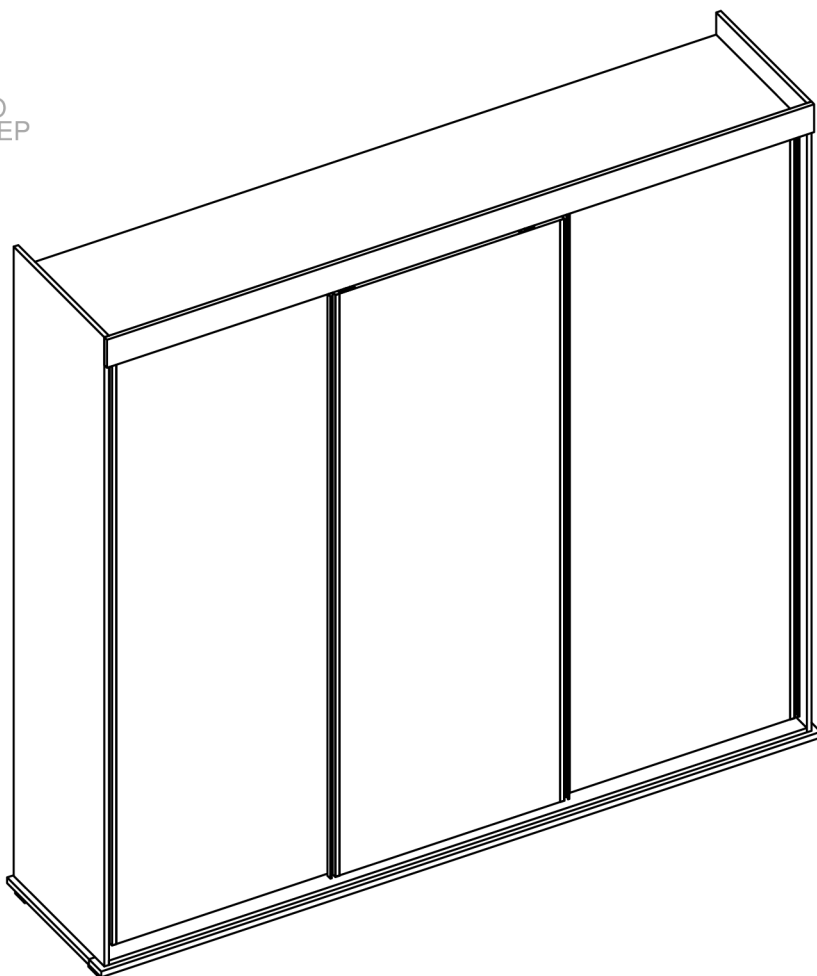

**IMPORTANTE:**

Utilize as ferramentas corretamente, evitando o uso de materiais que possam causar danos ao produto.



NOTA: "reservamos o direito de fazer modificações de ordem técnica neste produto, sem prévia notificação."

FÊNIX INDÚSTRIA DE MÓVEIS  
R: FRUTUOSO H. DE MEDEIROS, 2-68 - DISTR. INDUSTRIAL III  
TEL.: (17) 3485-1253  
VALENTIM GENTIL - SP/ CEP 15520-000  
E-MAIL: [fenix@camasfenix.com.br](mailto:fenix@camasfenix.com.br) / [www.camasfenix.com.br](http://www.camasfenix.com.br)

